



## Caution

Please Do Not Operate This Product Until You Have Read and Fully Understood the Instructions

.....

# Disc Flattener DF-2

## Users Manual

.....

Version : 2012/4

Furutech Co., Ltd.  
3F, 7-11-1 Nishi-Gotanda, Shinagawa-ku, Tokyo 141-0031, Japan  
Tel +81-3-5437-0281  
Fax +81-3-5437-8470  
[www.furutech.com](http://www.furutech.com)

## **IMPORTANT SAFETY INSTRUCTIONS**

WHEN USING YOUR DF-2 BASIC PRECAUTIONS SHOULD ALWAYS BE FOLLOWED, INCLUDING THE FOLLOWING:

1. Read all instructions.
2. Operate DF-2 for its intended purpose only.
3. To reduce the risks of electric shock do not immerse the unit in water or other liquids.
4. Never pull power cord to disconnect unit from wall outlet. Instead grasp plug and pull to disconnect.
5. Do not allow power cord to touch hot surfaces; let the DF-2 cool completely before storing.
6. Do not operate unit with a damaged power cord, or if the unit has been dropped or damaged. To reduce the risk of electric shock do not disassemble or attempt to repair the DF-2; take it to a qualified service technician for examination and repair. Incorrect reassembly or repair could cause a risk of fire, electric shock, or injury when the DF-2 is used.
7. Close supervision is necessary for any electrical component used by or near children. Do not leave DF-2 unattended while powered on.
8. Beware of hot metal parts.
9. To reduce the likelihood of circuit overload, do not operate another high-voltage appliance on the same circuit.

## **SAVE THESE INSTRUCTIONS**



WARNING

Misuse of electrical equipment displaying this mark may cause serious injury



CAUTION

Misuse of electrical equipment displaying this mark may be deadly



CAUTION

- Do not place anything other than vinyl LPs in the DF-2. Doing so may cause fire, electric shock or damage the product. If something other than a vinyl LP is placed in the DF-2, unplug it and let the DF-2 cool before removing it.
- It is not recommended that you treat your most valuable LP on the first try.
- Do not place foreign objects on the DF-2
- Do not place foreign objects in any open gaps or other openings of the DF-2
- Do not replace any parts with those that have not been specified by the manufacturer.
- Do not allow the DF-2 to be repaired by anyone but an approved service technician. Please contact your dealer for details.
- Before use, be sure the surrounding area is free of liquids, chemicals and heavy objects. Spilled liquids or chemicals may cause electrical shorts or fire.
- Remove the AC mains plug from the wall outlet if there is smoke, a burning odor, or if the DF-2 is knocked over. Used in these conditions the DF-2 may cause electrical shorts or fire.

# Contents

• Package Contents	1
• Description	2
• Caution	3
• Instructions	4
• Flattening Procedure Chart	5
• Specifications	6

# 1. Package Contents

LP Flattener (DF-2)	x 1
Heater Plate protective cloth	x 1
Manual	x 1
Caution note	x 1
Power cable	x 1
Duster	x 1

## 2. DF-2 Description

The DF-2 Flattener is designed to flatten LPs that have warped over time but not those that have been heat damaged. This is an improved version of the previous DFV-1 and has been carefully designed to flatten heavier LPs with no beads on their outer circumference. The DF-2 has improved time and temperature control to lessen the influence of seasonal temperature changes on the heating process. Caution: Before attempting to flatten any rare or valuable LPs, please test and become familiar with the operation of the DF-2 on an LP of no value. Results cannot be guaranteed and LPs cannot be returned to perfect condition.

Generally there are three types of LP discs (33 1/2 rpm):

1. Lightweight LPs (120g approx.)
2. LPs with groove guards: All but a few manufacturers' LPs are treatable.

Note: The following LPs should not be treated in the DF-2.

- LPs weighing less than 110g
- Light LPs that were manufactured between 1973-74 (Oil crisis) weights range from 100g to 115g.

3. Conventional middleweight LPs (140g approx.)

LPs with groove guards: All but a few manufacturers' LPs are treatable.

4. Heavyweight LPs (190g approx.)

**Heavy LPs without groove guards are now treatable.**

### 3. Caution

- Do not dismantle or modify the DF-2 which may cause the product to malfunction and render the manufacturer's warranty void.
- We recommend that you do not treat your most valuable LP on the first try.  
On first use we advise trying the product with an LP of no value.
- Furutech accepts no liability if the customer is for whatever reason not satisfied with the results produced by the DF-2 or if a customer's LP is damaged.
- Handle with care: The DF-2 is a relatively heavy component (12kg) with somewhat fragile heating plates. Furutech does not accept any liability if the user is injured while using or moving the DF-2.
- When moving the DF-2 the user should always close the heating plates and lock the side latches. The provided protective cloth should be placed on the heating plates when the unit is moved. Please remove the protective cloth during use.
- Do not cover the DF-2; make sure it is properly ventilated.
- Keep unit out of the reach of children.
- LPs that cannot be and should not be treated with the DF-2 are as follows:  
Flexi-disc, EP versions, SP versions and those LPs made with special materials cannot be treated with the DF-2.

At present it is known that the following manufacturers' LPs are not suitable for flattening by the DF-2 and treatment should not be attempted: Super Analog Discs, SHEFFILD LAB and BMG-UFA.

Note: The following LPs should not be treated in the DF-2.

- LPs weighing less than 110g
  - Light LPs that were manufactured between 1973-74 (Oil crisis) weights range from 100g to 115g.
- 
- The DF-2 has been specifically developed so 180gm LPs may also be safely and effectively treated. Please be sure to test on an LP of no value before use on rare and valuable LPs. Results cannot be guaranteed.
  - If an LP is not corrected after the first treatment then it cannot be treated with the DF-2. Do not carry out repeat treatments. This could damage the LP.

## 4. Instructions

1. Place the DF-2 on a level, stable surface as seen in the illustration below. Connect the provided AC cord, and then unlock both latches.
2. Gently open the clamshell heating plates. The plates can only open 30 degrees and can be locked in an open position using the side support bar.
3. Do not use excessive force.
4. Carefully set the LP on the center spindle.
5. To unlock the side support bar open the top plate to its fullest and close gently.

**DO NOT LOCK TRANSPORT LATCHES DURING FLATTENING PROCEDURE.**  
They are for storage and transport only

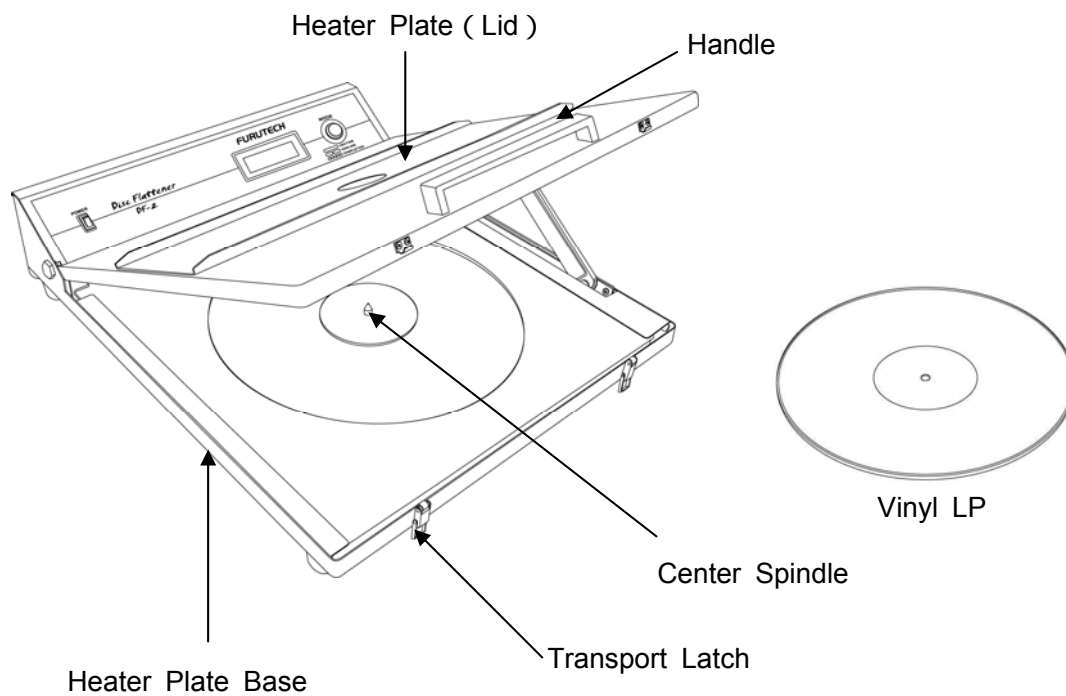

## Procedure

1. After switching on the power the Start display will flash and in about 5 seconds the standby screen appears.



Start Screen

2. Heating begins after pressing the mode button. By pressing the mode button a second time within 5 seconds of first pushing it, the Heating selection screen will show and you can change the heating time (1hr, 1½hr, 2hr, 2½hrs). If the mode button is not pushed a second time within 5 seconds then the preset heating time (1½hrs) begins.



Stand by screen

*In warm climates 1hr ~1½hrs is recommended and in cold climates 2~2½hrs is recommended. There is the possibility of damaging LPs with long period treatments, so please be sure to test on an LP of no value first. Results cannot be guaranteed.*



Time Selection Screen

During the heating process the heating screen displays. As long as the power switch is not turned off during the heating period, this screen will remain. Do not move or open the DF-2 during the heating process. Do not lock the latches during treatment.

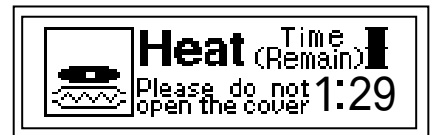

Heating Screen

3. Once the heating stage of the process is complete, the cooling screen will be displayed. The cooling process is set at 2hrs. The heating process may be interrupted by pressing the mode button for more than three seconds. The cooling process will then automatically begin. Do not open the DF-2 during the cooling process.



Cooling Screen

4. Once the cooling stage of the process is completed, a tone will sound indicating completion and the mode button will flash. After confirming completion the LP may be removed from the DF-2.



Completion Screen

5. Pressing the mode button shows the completion screen and that returns to the standby screen.

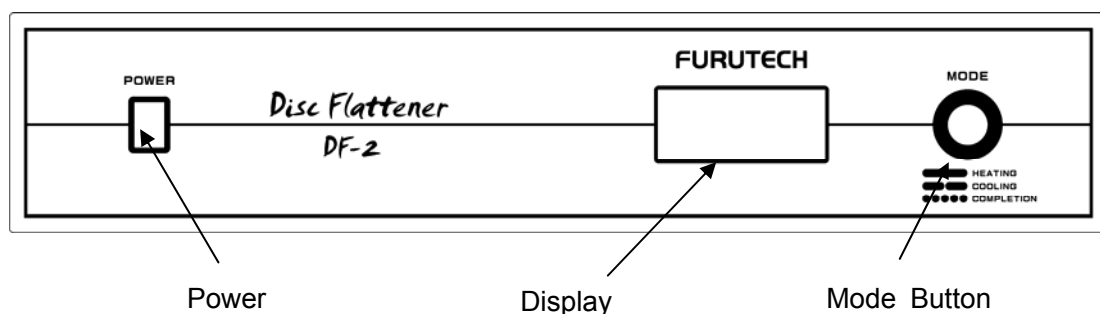

6. Should the device sense an abnormality during the heating process, the process will automatically stop and the cooling process will begin. An alarm will sound for 10 seconds to notify this change. To stop the alarm press the mode button.



**Error Screen**

An Error sign will show on the display screen.

Caution: Do not open the cover until the cooling process is complete.

7. Once the cooling process is complete the alarm will sound for 10 seconds. Press the mode button to stop the alarm. The display screen will show an "Error Finish" image.

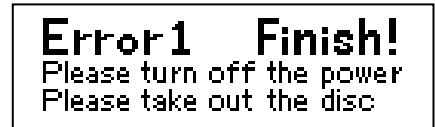

**Error Cooling  
Completion Screen**

Error 1. High temperature abnormality (Temperature too high)

Error 2. Sensor abnormality (sensor fault)

Error 3. Heating abnormality (not heating correctly)

8. If any of these errors are experienced, please contact the dealer from where you purchased or the manufacturer.



## 5. Flattening Procedure Flow Chart

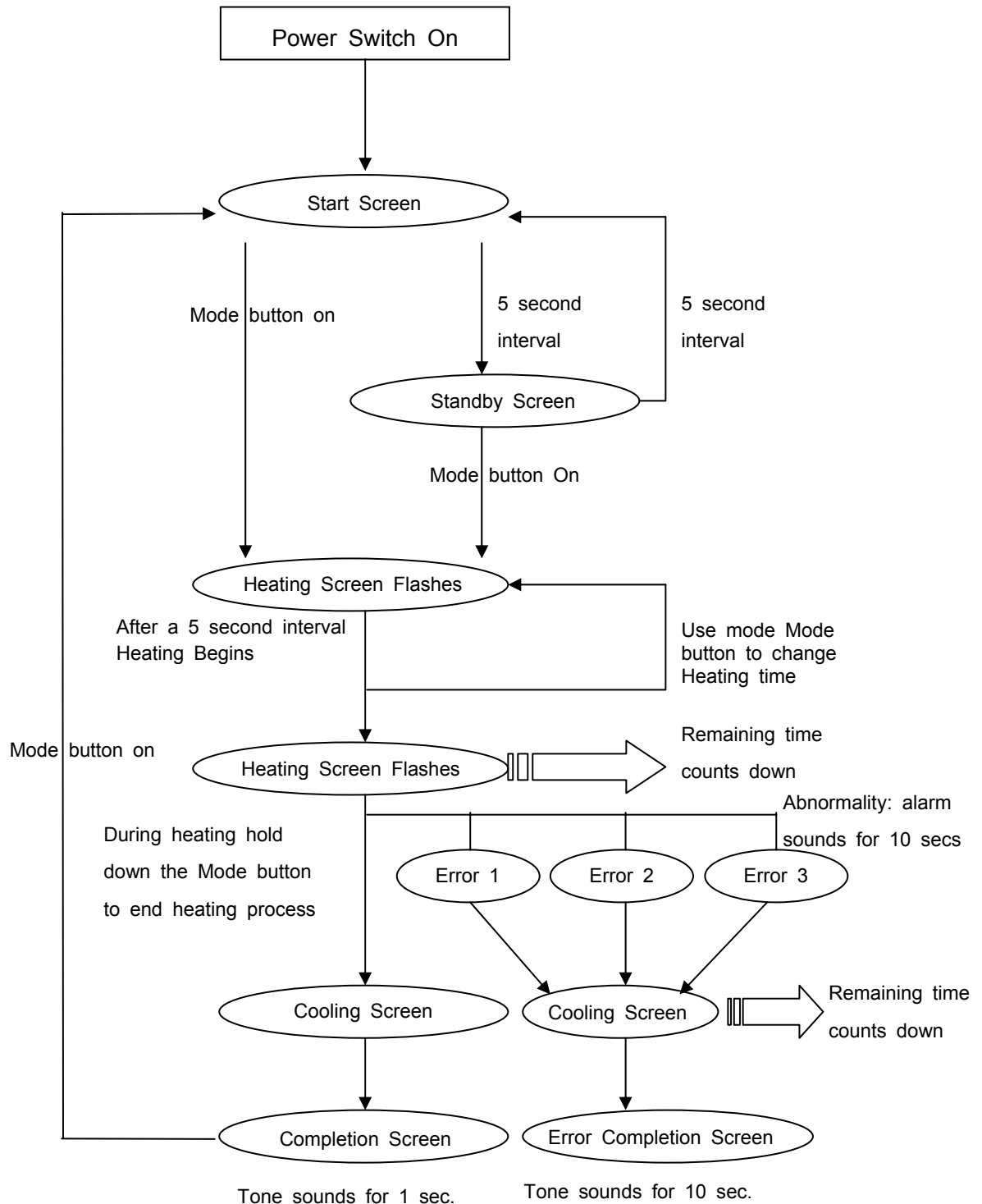

### ●Cooling Time

- Normal : 2 hours
- Error1 : 2 hours
- Error1 : 1.5 hours
- Cooling will begin if there is a Sensor Abnormality or the Mode button is held down

Heating Time	5mins	10mins	20mins	20mins plus
Cooling Time	5mins	40mins	1hr40mins	2hrs

## 6. DF-2 Specifications

Rating . . . . . 115V ± 10% AC Line 5A fuse

European model . . . . . 230V ± 10% AC Line 3A fuse

Energy Consumption . . . . . 460W (max)

Heating plate maximum temp. . . . . 57 ± 3

Size: 445mm/17" W x 117mm/20" H x 547mm/7" D • Weight: 12kg/22lbs approx.

Safe Usage Environment:

Humidity 20% - 90% (No condensation)

Temperature: 5C/41F – 35C/95F

Manufactured for Furutech by ORB High End Systems of Japan

**Furutech Co., Ltd.**

**3F, 7-11-1 Nishi-Gotanda, Shinagawa-ku, Tokyo 141-0031, Japan**

**Tel +81-3-5437-0281**

**Fax +81-3-5437-8470**

**Contact: [service@furutech.com](mailto:service@furutech.com)**

**[www.furutech.com](http://www.furutech.com)**

**FURUTECH**  
www.furutech.com  
**LIMITED WARRANTY**

Serial No.

MODEL No. DF-2 LP Flattener

This product is made of high quality materials and great care has been taken in its manufacture. It is designed to give good performance provided it is properly operated and maintained. This product is sold subject to the understanding that if any defect in manufacture or material shall appear within 12 months from date of consumer sale, Furutech will arrange for such defect to be rectified without charge provided that: The defect is not due to use of the product for other than domestic purposes, or on an incorrect voltage, or contrary to operating instructions, or to accidental damage (whether in transit or otherwise), misuse, neglect or inexpert repair, or incorrect installation.

This guarantee card does not cover accessories belonging to the product.

No alteration of this guarantee card will be allowed.

For service enquires please call your local dealer or distributor.

*Important notice: For free repair service please keep this guarantee card and invoice in a safe place.*

-----

Serial No.

Please fill out and return to Furutech's local dealer

Model No : .....

Customer's Name : .....

Address : .....

Tel No. : .....

Date of purchase : .....

Store where purchased : .....

E-mail Address : .....

